

Transmisión automática

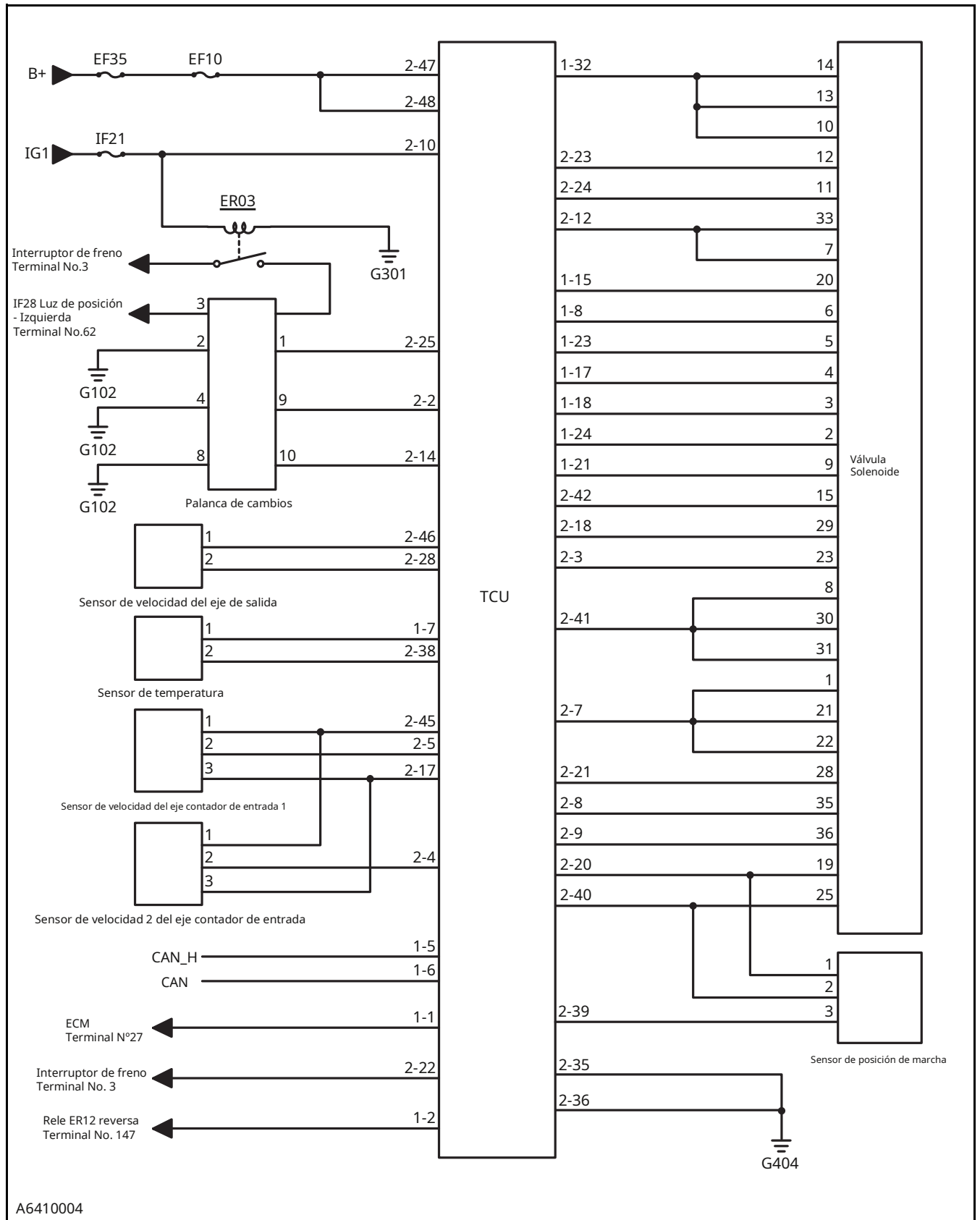

A6410004

Fuente de alimentación/cambiador

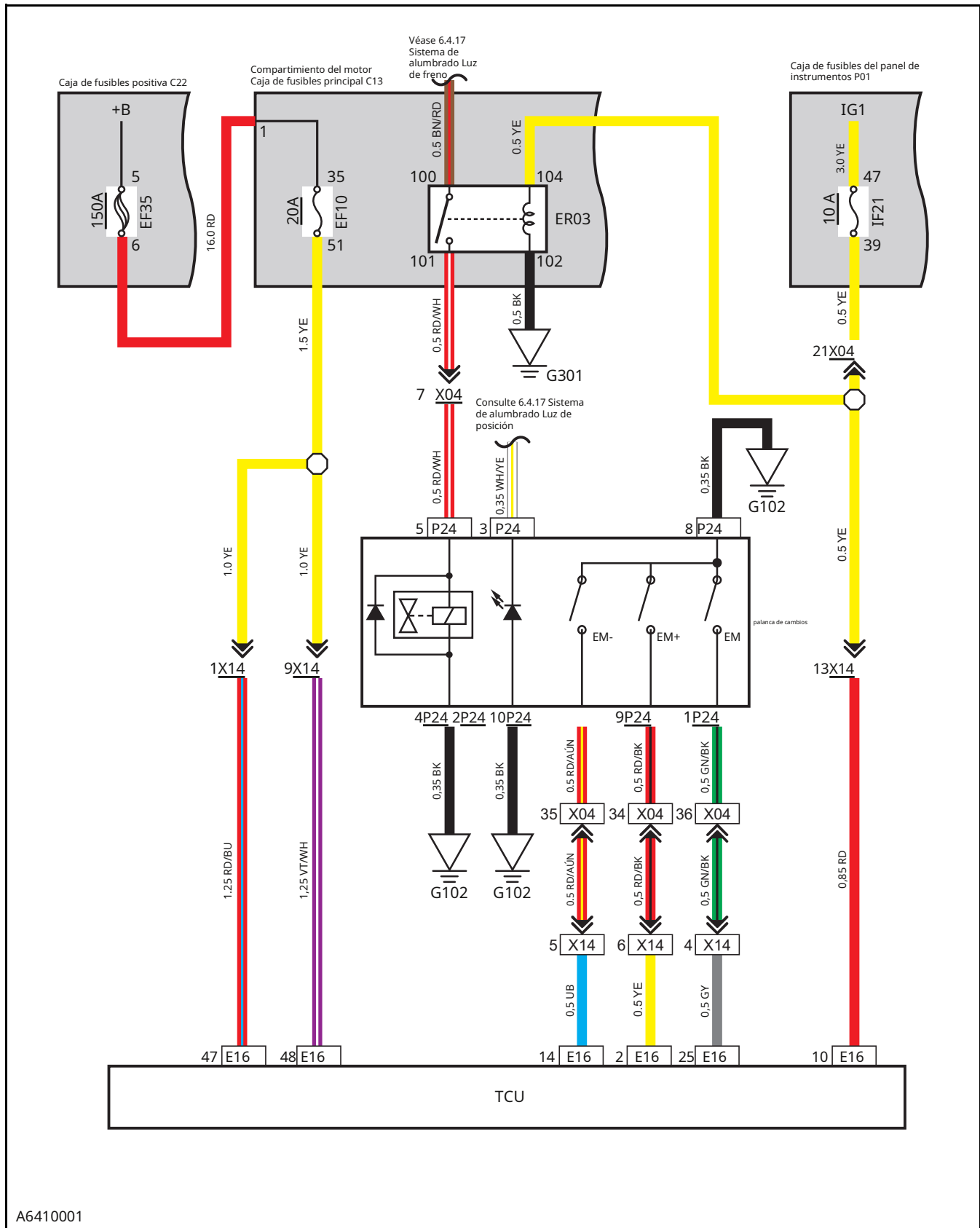

Sensor de velocidad del eje de salida/Sensor de velocidad del eje 1 del contador de entrada/Sensor de velocidad del eje 2 del contador de entrada/Sensor de temperatura/Sensor de posición del engranaje

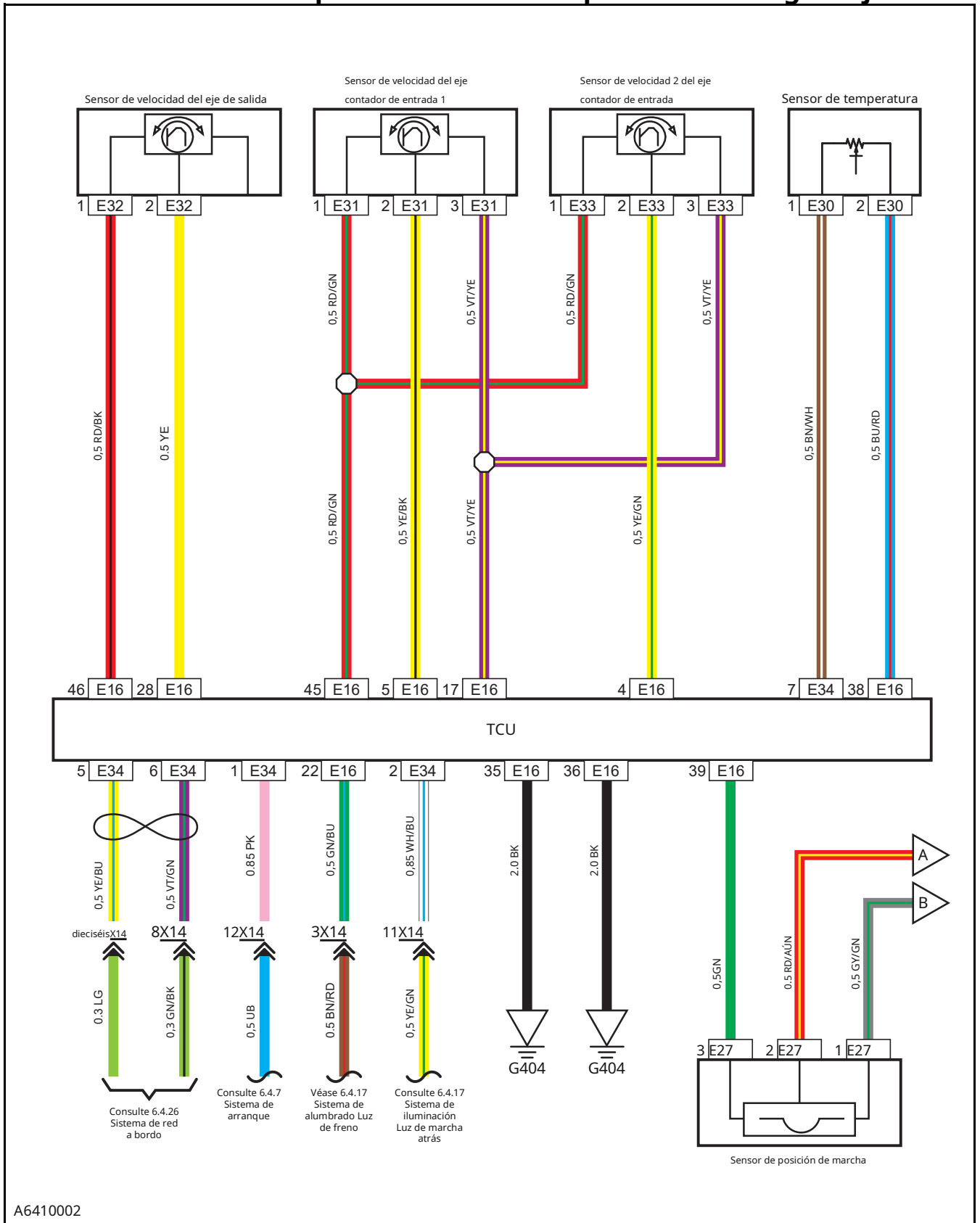

A6410002

Válvula solenoide

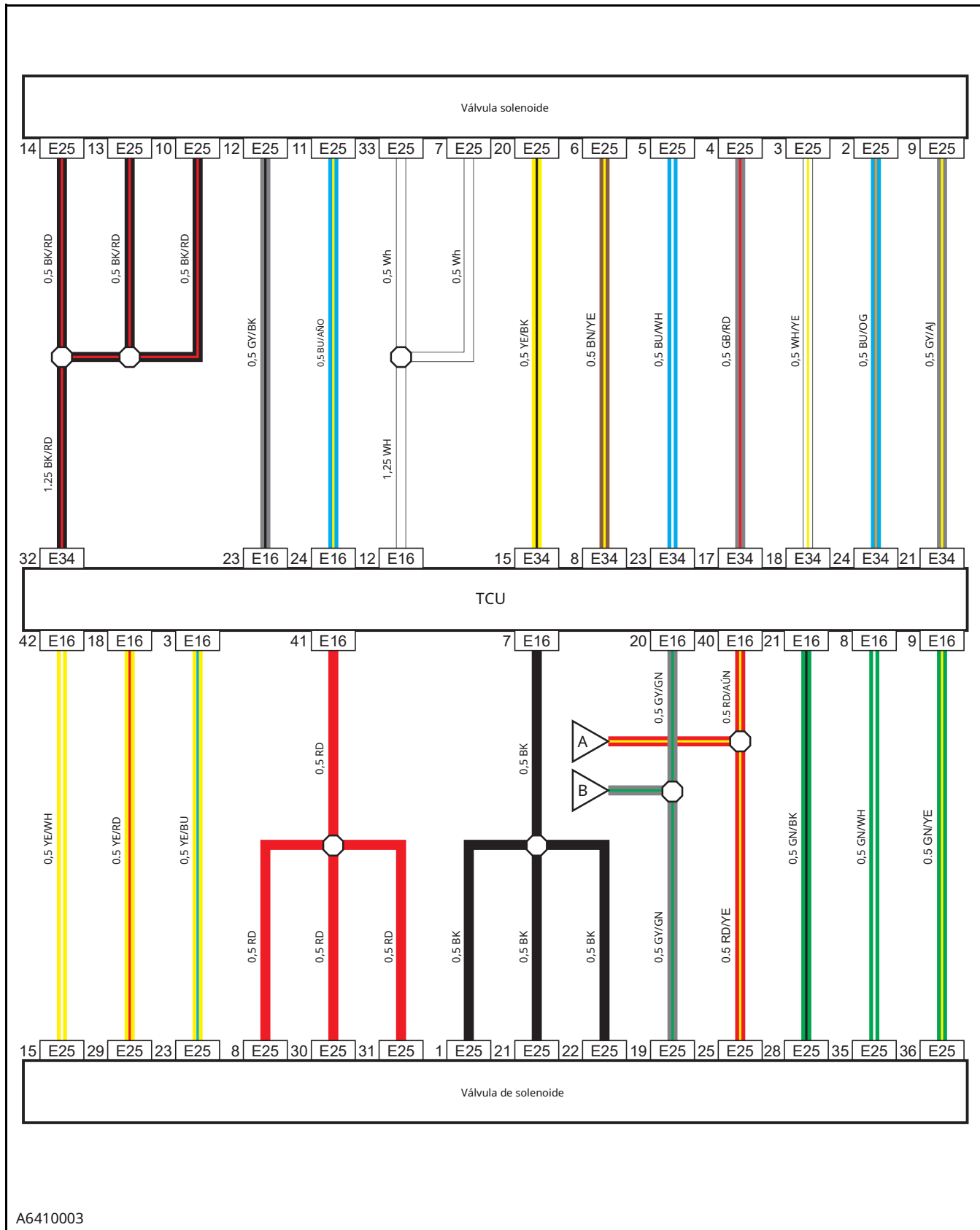

A6410003

Caja de fusibles principal del compartimento del motor

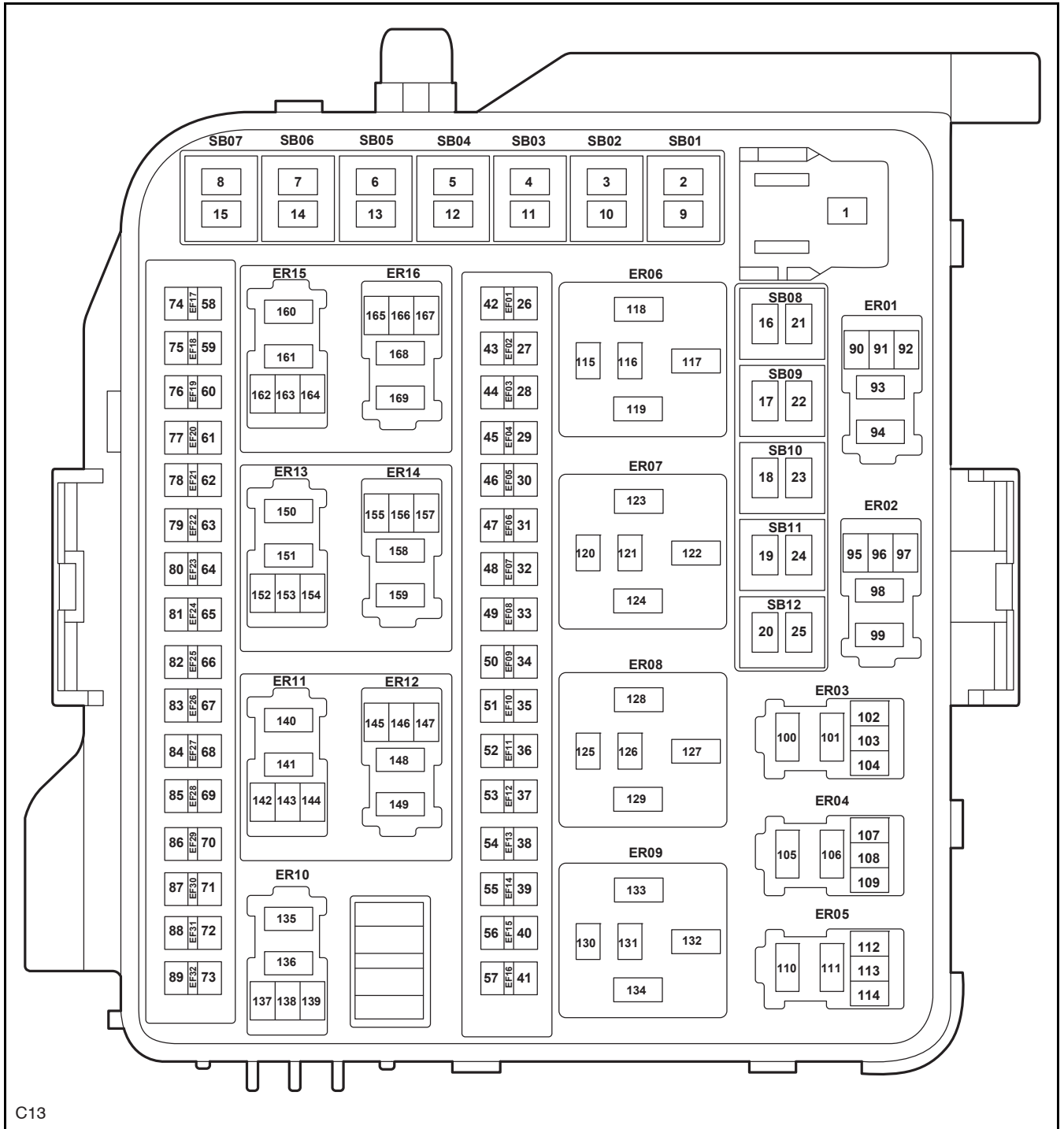

C13

Caja de fusibles del panel de instrumentos

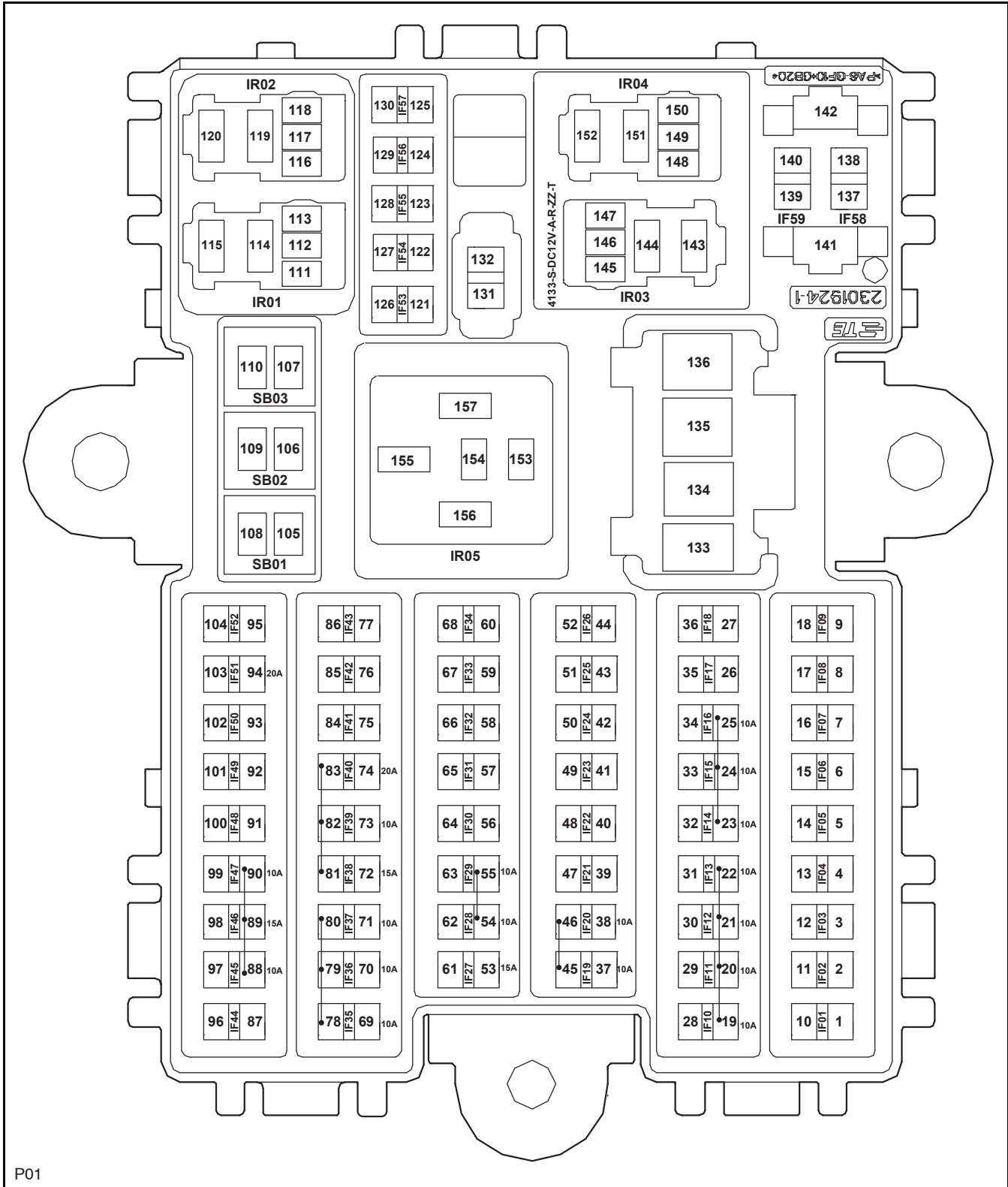

P01

Mazo de cables del compartimento del motor al mazo de cables del panel de instrumentos - Izquierda

Mazo de cables del panel de instrumentos al mazo de cables del compartimento del motor - Izquierda

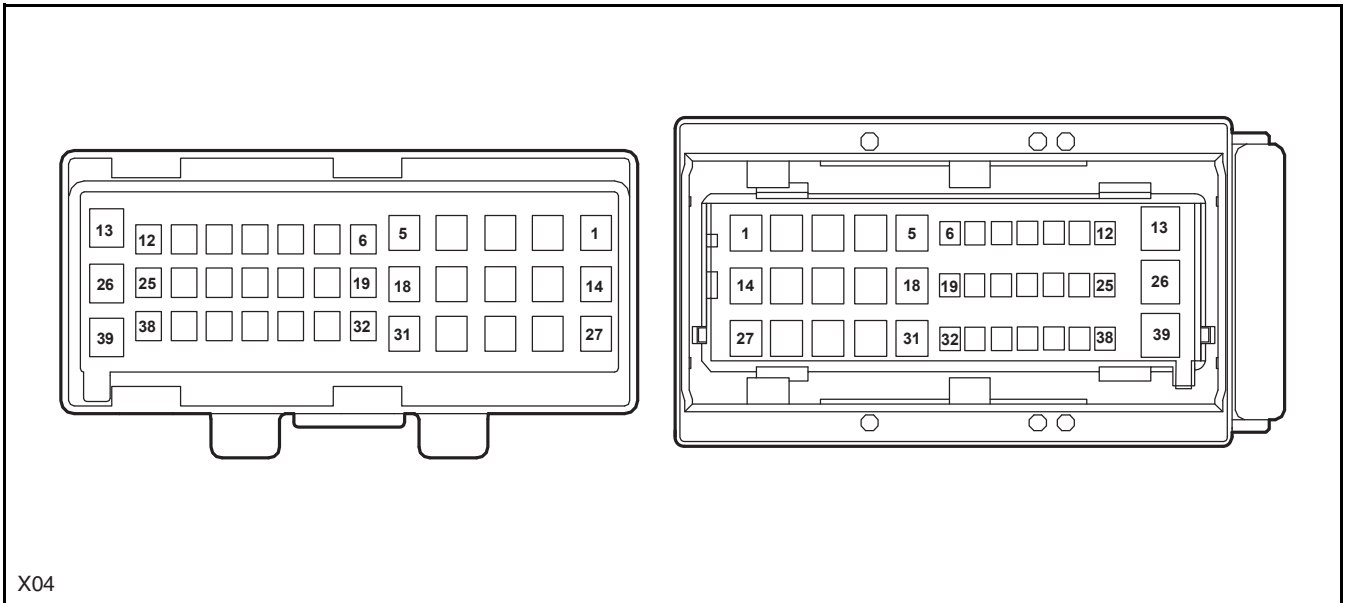

X04

Mazo de cables del compartimento del motor al mazo de cables de la TCU

Mazo de cables de la TCU al compartimento del motor

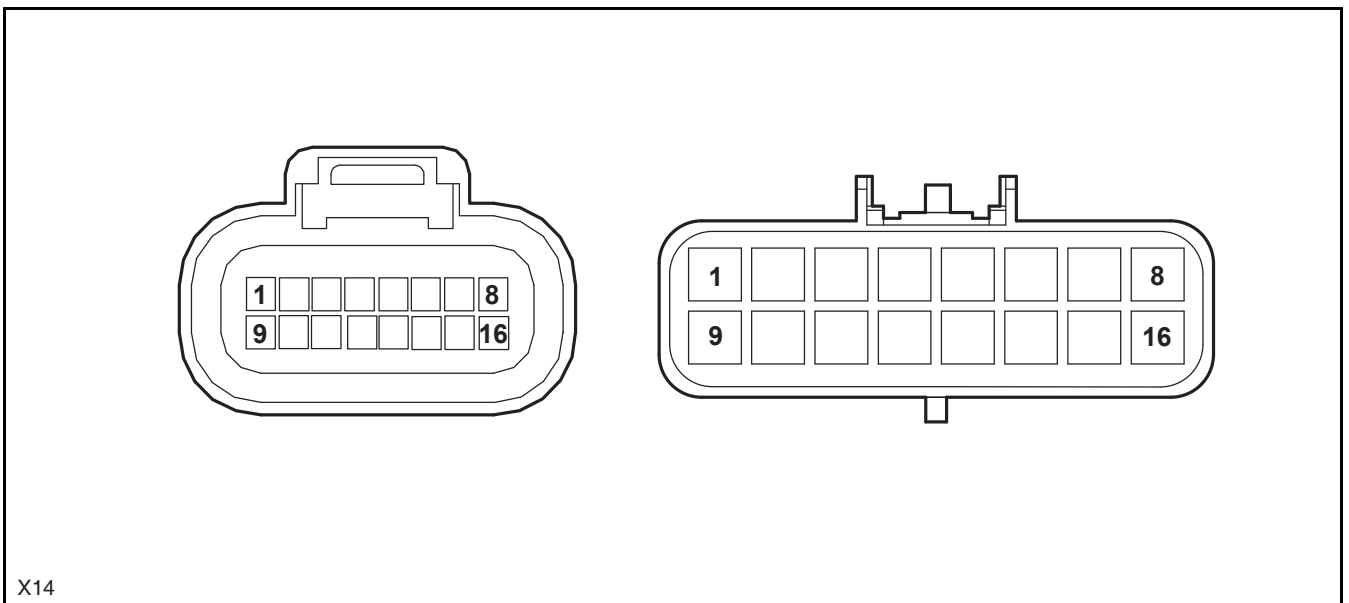

X14

Caja de fusibles positiva

Palanca de cambios

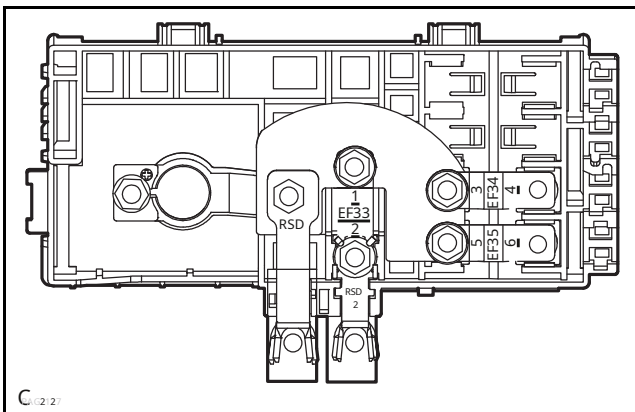

C12:2

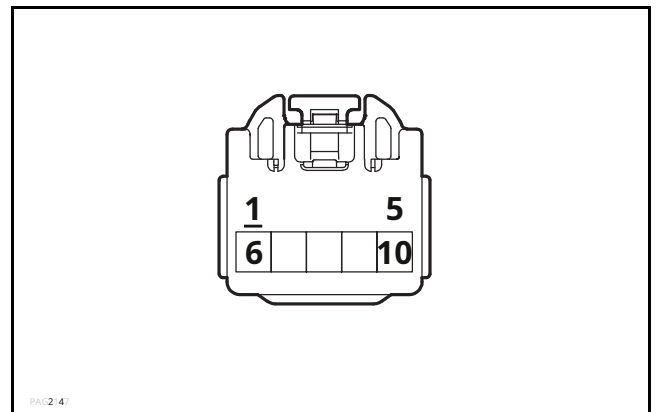

PA2:4

TCU B

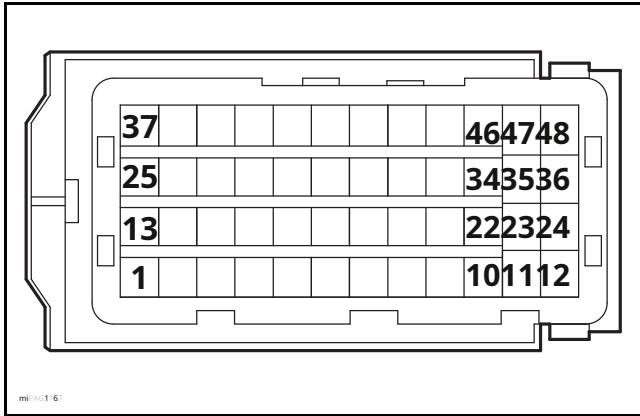

Sensor de velocidad del eje de salida

TCU A

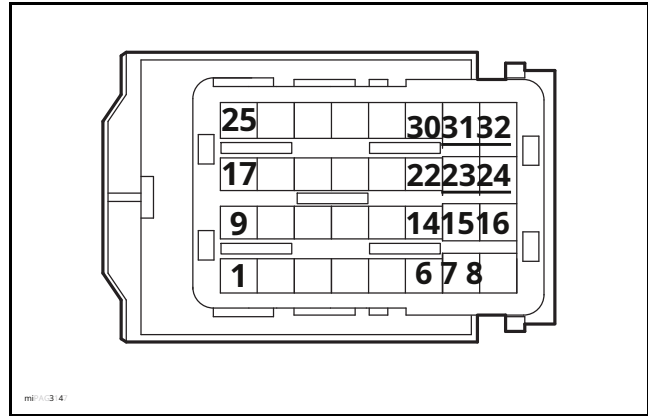

Sensor de velocidad del eje contador de entrada 1

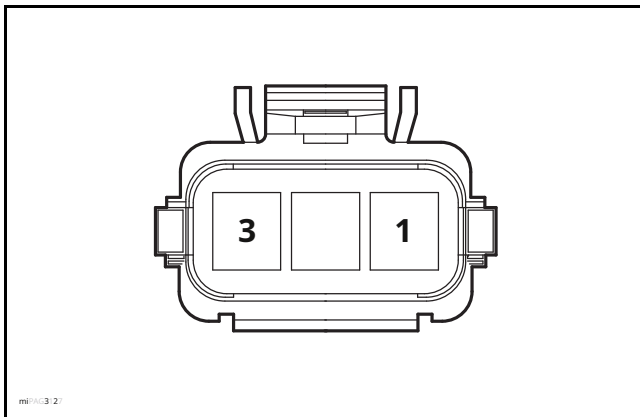

Sensor de velocidad 2 del eje contador de entrada

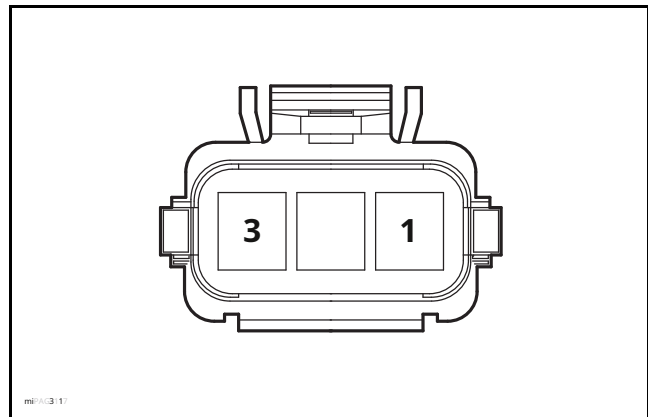

Sensor de temperatura

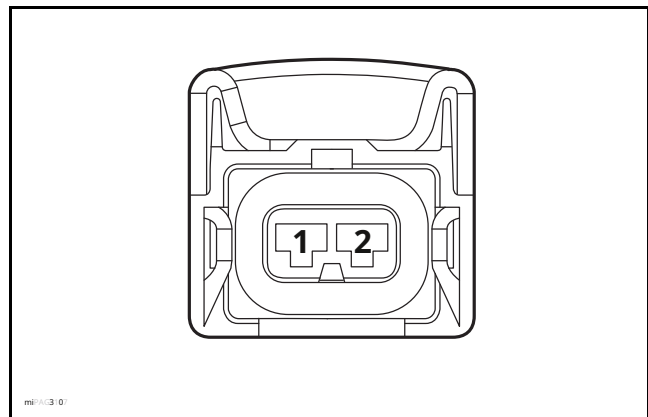
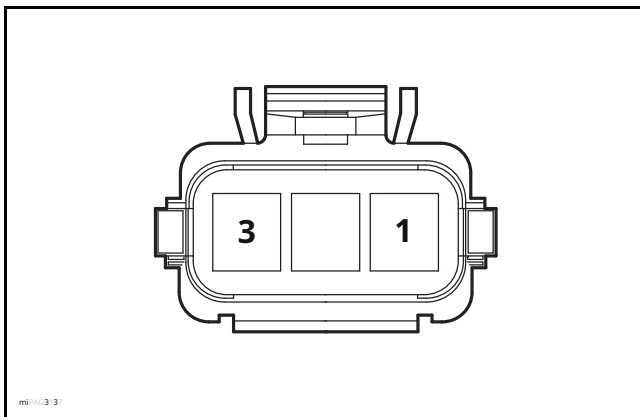

Sensor de posición de marcha

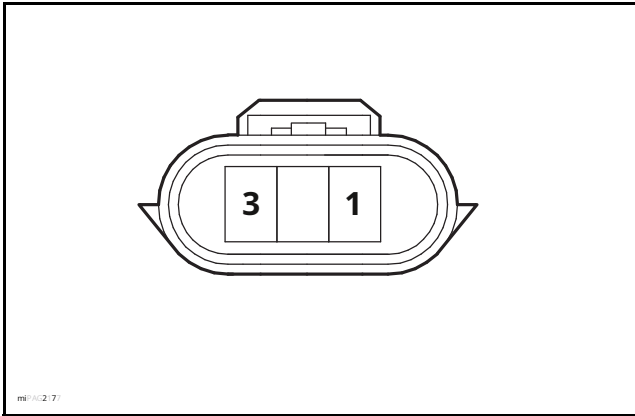

Válvula de solenoide

